



***System Impact Study for
Generation Interconnection
Request***

GEN-2003-005

***SPP Tariff Studies
(#GEN-2003-005-2)***

September, 2005

Summary

Black & Veatch performed the following re-Study at the request of the Southwest Power Pool (SPP) for Generation Interconnection request GEN-2003-005. The request for interconnection was placed with SPP in accordance with SPP's Open Access Transmission Tariff, which covers new generation interconnections on SPP's transmission system.

Pursuant to the tariff, Black & Veatch was asked to perform a detailed stability analysis of the generation interconnection request to satisfy the Impact Study Agreement executed by the requesting customer and SPP. This re-study was conducted due to request by the Customer to change the manufacturer of the wind turbines at the wind farm.

The Federal Energy Regulatory Commission finalized the grid-interconnection rule for large wind power facilities May 25, 2005. The final rule provides that wind generators must meet the following conditions, if the transmission service provider demonstrates they are needed. First, if needed, a large wind generating facility must remain operational during voltage disturbances on the grid. Second, large wind plants must, if needed, meet the same technical criteria for providing reactive power to the grid as required of conventional large generating facilities. Third, the final rule provides for supervisory control and data acquisition (SCADA), if needed, to ensure appropriate real-time communication and data exchanges between the wind power producer and the grid operator.

To this end SPP recommends that the Customer strongly consider these reliability requirements of the wind farm based on the FERC final rule.

On September 19, 2005, the American Wind Energy Association (AWEA) and NERC jointly made a filing at FERC recommending that all wind generators be able to ride through all faults with voltage drops up to zero volts for up to 9 cycles.

Due to the under-voltage trips noted in the stability results in Table 7 and in keeping with both the FERC final rule and AWEA/NERC recommendations, the Customer shall purchase the Advanced Grid Option 4 (AGO4) protection package offered for the Vestas turbines in order to continue operation during grid faults.

Due to the voltage oscillations encountered when using the AGO4 protection package, the generation interconnection is not acceptable to be interconnected at the requested point without either system reinforcements, an SVC at the customer's substation, or a reduction of the initial generation interconnection request of 100 MW.

In order for the request to continue on to the Facility Study process the Customer must either -

- Agree to install a 34.5kV, 30MVAR SVC in the Customer's interconnection substation as detailed in the Black & Veatch report.
- Agree to the necessity of adding system reinforcements to accommodate the request. The system reinforcement being recommended is an additional 138kV line from WFEC interconnection substation to Anadarko power station, a distance of approximately 30 miles. Documentation of this option is not included in the Black & Veatch report but can be supplied on request.
- Agree to lower the capacity of the generation request. Preliminary studies show the facility would only be able to accommodate 60MW of generation without an SVC or system reinforcements. Documentation of this option is not included in the Black & Veatch report but can be supplied on request.

Additionally, if the Customer chooses an option that does not include the 30 MVAR SVC, a 10MVAR capacitor bank shall be installed at the Customer interconnection substation in order for the facility to maintain unity power factor at the point of interconnection as detailed in the report.

**IMPACT STUDY FOR SPP GENERATION
QUEUE POSITION GEN-2003-005**

**SOUTHWEST POWER POOL (SPP)
September 21, 2005**

By



BLACK & VEATCH

Table of Contents

<i>EXECUTIVE SUMMARY</i>	3
<i>1. INTRODUCTION</i>	4
<i>2. STABILITY STUDY CRITERIA</i>	4
<i>3. SIMULATION CASES</i>	5
<i>4. SIMULATION MODEL</i>	7
<i>5. STUDY ASSUMPTIONS</i>	10
<i>6. SIMULATION RESULTS</i>	11
<i>7. SUMMARY</i>	13

EXECUTIVE SUMMARY

A transient stability study has been performed for Southwest Power Pool (SPP) Interconnection Queue Position Gen-2003-005 as part of the System Impact Study. The Interconnection Queue Position Gen-2003-005 is a wind farm of 100 MW capacity proposed to be connected to a new switching station to be constructed on the Western Farmers Electric Cooperative (WFEC) 138 KV Anadarko – Paradise line near Apache, Oklahoma. The wind farm would be interconnected to the switch station with a 4 mile radial 138kV line.

Transient Stability studies were conducted with the full output of 100 MW (100%). The wind farm was considered to contain Vestas V80-1.8 MW turbines in the study.

The 2009 summer load flow case and 2006 winter load flow case together with the SPP MDWG 2003 stability model were used as the base case for the transient stability analysis. The study was performed using PTI's PSS/E program, which is an industry-wide accepted power system simulation program. The wind farm was modeled using the Vestas wind turbine models available within the the PSS/E program.

Prior to the transient stability analysis, a power flow analysis was conducted to estimate the amount of additional shunt capacitors that would be needed at the wind farm 34.5 kV collector buses so as to have zero reactive power exchange between wind farm and the grid. It was found that about 10 MVAR capacitors would be needed in the summer peak load case.

Transient Stability studies were conducted with the Gen-2003-005 output at 100 MW (100%) for two scenarios, i.e., (i) summer load and (ii) winter load. Twenty Two (22) contingencies were considered for each of the scenarios.

The study has indicated that the Vestas V80-1.8 MW turbines will have to be provided with the optional AGO4 voltage ride through scheme in order to continue the operation during the grid faults. However, the study has indicated voltage stability problem for a fault near Anadarko on Anadarko – Gen-2003-005 Wind Farm 138 kV line. A Static VAR Compensator (SVC) of +30 MVAR would be needed at Gen-2003-005 Windfarm's 34.5 kV collector bus, so as to avoid the transient voltage stability problem.

The Interconnection Customer shall consider this additional risk implication of wind farm outages that the wind turbine under voltage control scheme may cause to the wind farm.

If any previously queued projects that were included in this study drop out then this System Impact Study may have to be revised to determine the impacts of this Interconnection Customer's project on SPS transmission facilities.

1. INTRODUCTION

This report discusses the results of a transient stability study performed for Southwest Power Pool (SPP) Interconnection Queue Position Gen-2003-005.

The Interconnection Queue Position Gen-2003-005 is a wind farm of 100 MW capacity proposed to be connected to a new switching station to be constructed on the Western Farmers Electric Cooperative (WFEC) 138 KV Anadarko – Paradise line near Apache, Oklahoma. The wind farm would be inter-connected to the switch station with a 4 mile radial 138kV line. The system one line diagram of the area near the Queue Position Gen-2003-005 is shown below.

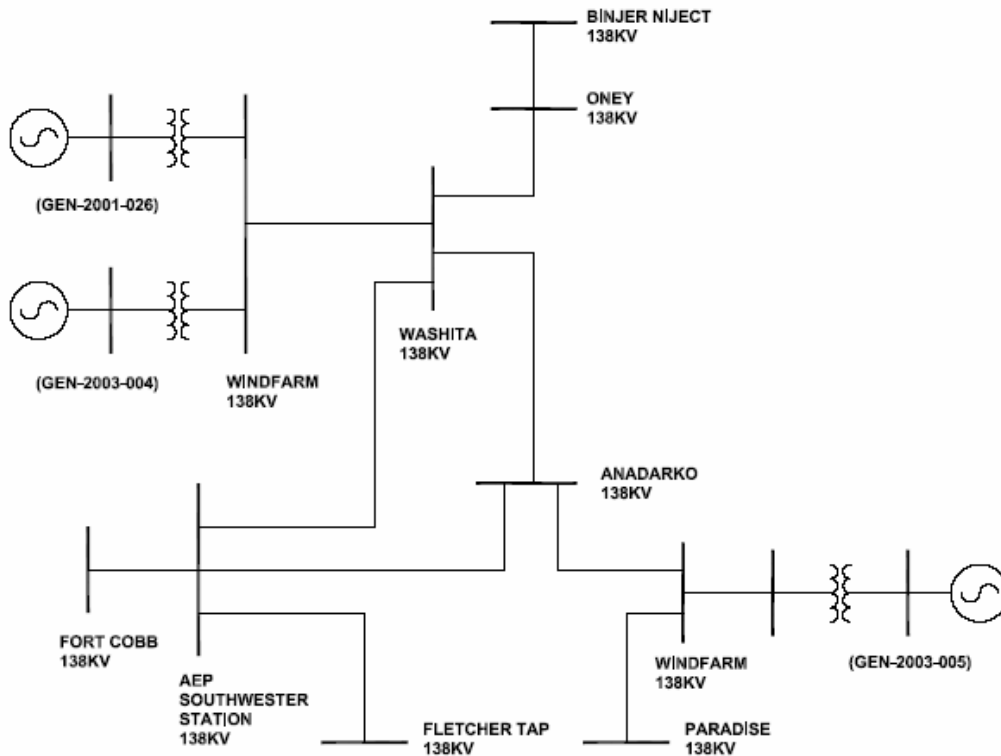

Figure 1 : System One Line Diagram near GEN-2003-005

Transient Stability studies were conducted with the full output of 100 MW (100%). The wind farm was considered to contain Vestes V80-1.8 MW wind turbines in the study.

2. STABILITY STUDY CRITERIA

The 2009 summer peak and 2006 winter load flow cases together with the SPP MDWG 2003 stability model were used as the base case for the transient stability analysis. These models were provided by SPP.

Using Planning Standards approved by NERC, the following stability definition was applied in the Transient Stability Analysis:

“Power system stability is defined as that condition in which the difference of the angular positions of synchronous machine rotor becomes constant following an aperiodic system disturbance.”

Disturbances such as three phase and single phase line faults were simulated for a specified duration and the synchronous machine rotor angles were monitored for their synchronism following the fault removal.

The ability of the wind generators to stay connected to the grid during the disturbances and during the fault recovery was also monitored.

3. SIMULATION CASES

Transient Stability studies were conducted with the Gen-2003-005 output at 100 MW (100%) for two scenarios, i.e., (i) 2009 summer peak load and (ii) 2006 light fall load.

Table 1 indicates the contingencies which were studied for each of the two cases.

Fault Number	Fault Definition
FLT13PH	Three phase fault on Anadarko – Wind Farm 138 kV line, near Anadarko, with one shot reclosing after 20 cycles.
FLT21PH	Single phase fault on Anadarko – Wind Farm 138 kV line, near Anadarko, with one shot reclosing after 20 cycles.
FLT33PH	Three phase fault on Paradise – Windfarm138 kV line, near Paradise, with one shot reclosing after 20 cycles.
FLT41PH	Single phase fault on Paradise – Windfarm138 kV line, near Paradise, with one shot reclosing after 20 cycles.
FLT53PH	Three phase fault on Snyder – Paradise 138 kV line, near Snyder, with one shot reclosing after 20 cycles.

FLT61PH	Single phase fault on Snyder – Paradise 138 kV line, near Snyder, with one shot reclosing after 20 cycles.
FLT73PH	Three phase fault on Snyder – Snyder 69kV line, near Snyder 69Kv, with one shot reclosing after 20 cycles.
FLT81PH	Single phase fault on Snyder – Snyder 69kV line, near Snyder 69Kv, with one shot reclosing after 20 cycles.
FLT93PH	Three phase fault on Fort Cobb – Southwestern Station 115 kV line, near Fort Cobb, with one shot reclosing after 20 cycles.
FLT101PH	Single phase fault on Fort Cobb – Southwestern Station 115 kV line, near Fort Cobb..
FLT113PH	Three phase fault on Anadarko – Southwestern Station 138 kV line, near Southwestern Station, with one shot reclosing after 20 cycles.
FLT121PH	Single phase fault on Anadarko – Southwestern Station 138 kV line, near Southwestern Station, with one shot reclosing after 20 cycles.
FLT153PH	Three phase fault on Anadarko – Blanchard 69 kV line, near Blanchard, with one shot reclosing after 20 cycles.
FLT161PH	Single phase fault on Anadarko – Blanchard 69 kV line, near Blanchard..
FLT173PH	Three phase fault on Washita – Anadarko 138 kV line, near Anadarko, with one shot reclosing after 20 cycles.
FLT181PH	Single phase fault on Washita – Anadarko 138 kV line, near Anadarko.
FLT193PH	Three phase fault on Washita – Oney 138 kV line, near Oney, with one shot reclosing after 20 cycles.
FLT201PH	Single phase fault on Washita – Oney 138 kV line, near Oney.
FLT213PH	Three phase fault on Washita – Wind farm 138 kV line, near the Wind farm, with one shot reclosing after 20 cycles.
FLT221PH	Single phase fault on Washita – Wind farm 138 kV line, near the Wind farm, with one shot reclosing after 20 cycles.
FLT233PH	Three phase fault on Washita – Southwester Station 138 kV line, near Washita, with one shot reclosing after 30 cycles.
FLT241PH	Single phase fault on Washita – Southwester

	Station 138 kV line, near Washita, with one shot reclosing after 30 cycles.
--	---

Table 1: Study Cases

In all of the simulations, the fault duration was considered to be 5 cycles.

4. SIMULATION MODEL

The customer requested that the System Impact Study for the project to include Vestas V80-1.8 MW wind turbines. The Vestas V80-1.8 MW turbines are a three phase induction generators with a proprietary rotor resistance control called “optislip control”. The following are the main electrical parameters of the Vestas V80-1.8 MW wind turbine.

Rated Power	: 1.8 MW
Voltage	: 690 V
Power Factor Correction	: 864 kVAR

The models of the Wind Farm equipment such as generators, transformers and cables were added to the base case for the purpose of this study. The equivalent generators of the wind farm were based on the number of collector circuits shown on the Customer provided single line diagram. Figure 2 shows the one line diagram of Gen-2003-005 modeled.

Table 2 provides the number of Vestes V80-1.8 MW wind generators modeled as equivalents at each collector buses of the wind farm.

Collector Bus	No. of generators aggregated
R3R8	6
T1T7	7
V14W13	7
U1U7	7
U17U20	4
T16T17	2
T8T15	8
U21U26	7
U8U15	8

Table 2 : Equivalent Generators with Vestas V80-1.8 MW Turbines

Table 3 indicates the transmission line parameters, as provided by the Customer, were used in the model for the underground lines within the Wind Farm and also between the Wind Farm and the Switching Station:

Conductor Size	Resistance (Ohms per 1000 ft)	Reactance (Ohms per 1000 ft)
1/0 AWG	0.212	0.055
4/0 AWG	0.107	0.049
1000 kcmil	0.028	0.037
500 kcmil	0.047	0.042

Table 3 : Cable impedance per 1000 feet.

The Customer also provided the following substation transformer's impedance:

Transformer Impedance : 9.0 % at 67 MVA

The prior queued projects Gen-2001-026 (74.3 MW) and Gen-2003-004 (100 MW) were also included in the study model.

A power flow analysis was conducted to estimate the amount of additional shunt capacitors that would be needed at the wind farm 34.5 kV collector buses so as to have zero reactive power exchange between wind farm and the grid. It was found that about 10 MVAR capacitors would be needed in the summer peak load case.

Gen-2003-005 was modeled using the Vestas V80-1.8 MW wind turbine model available in PSS/E. The data used in the study is as noted in Table 3.

Figure 2 shows the 100% base case power flow for the project GEN-2003-005.

Description	Value
Stator resistance, Ra	0.0049 pu
Stator inductance, La	0.126 pu
Mutual inductance, Lm	6.8399 pu
Rotor resistance	0.0887 pu
Rotor inductance	0.1808 pu
Generator inertia	0.644 sec
Damping factor	0.0 pu
Shaft stiffness	0.92 pu
Turbine rotor inertia	0.1 sec
Number of generator pole pairs	2
Gear box ratio	120.6

Table 4 : Vestas V80-1.8 MW Wind Turbine Generator Parameters

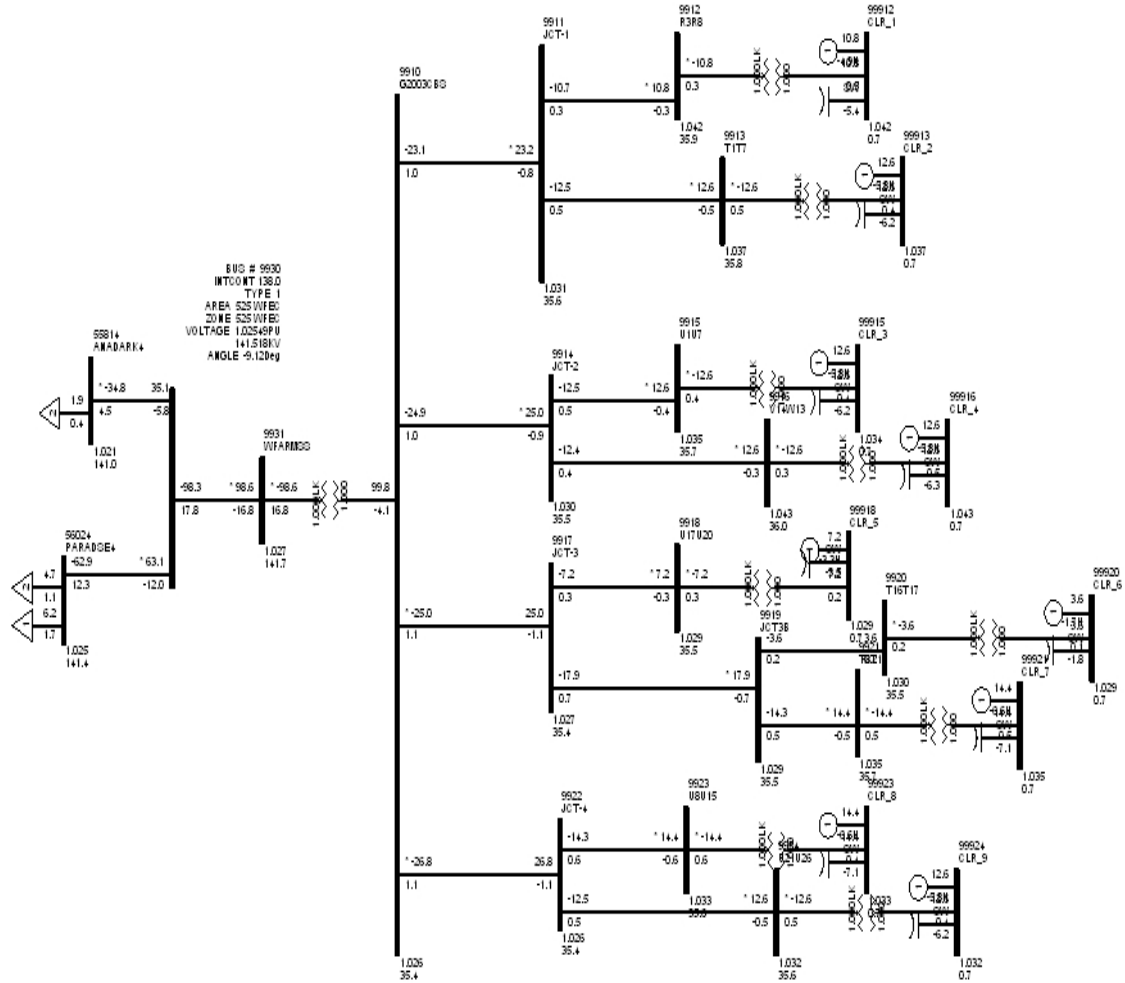

Figure 2 : 100% Power Flow Base Case for GEN-2003-005

5. STUDY ASSUMPTIONS

The following assumptions were made in the Study:

1. The wind speed over the entire wind farm was assumed to be uniform and constant during the study period.
2. The turbine control models available within PSS/E were used with their default values.
3. From the wind turbine data sheets the protection settings were used as and are shown in Table 5.

4. The other generators in the SPP control area were scaled down to accommodate the new generation as indicated in Table 6.

Protective Function	Protection Setting	Time Delay
Over Frequency	62.0 Hz	0.2 seconds
Under Frequency	57.0 Hz	0.2 seconds
Under Voltage	75%	0.08 seconds
Under Voltage	85%	0.4 seconds
Under Voltage	94%	60.0 seconds
Over Voltage	110%	60.0 seconds
Over Voltage	113.5%	0.2 seconds
Over Voltage	120%	0.08 seconds

Table 5 : Standard Protective Functions and Settings for Vestas V80-1.8 MW Turbines

Scenario	Generation within SPP	
	Summer	Winter
Without the Wind Farms	36876	21172
Gen-2003-005 at 100% output with the prior queued projects	36604	20899

Table 6 : SPP Dispatches

6. SIMULATION RESULTS

Initial simulation was carried out without any disturbance to verify the numerical stability of the model and was confirmed to be stable.

Table 7 provides the summary of the stability studies for Gen-2003-005.

Fault Number	Summer Load	Winter Load
FLT13PH	UV, PQ-1	UV, PQ-1
FLT21PH	UV	UV, PQ-1
FLT33PH	UV	UV
FLT41PH	--	UV
FLT53PH	UV	UV
FLT61PH	--	--
FLT73PH	--	--
FLT81PH	--	--
FLT93PH	UV, PQ-1	UV, PQ-1

FLT101PH	--	UV, PQ-1
FLT113PH	UV, PQ-1	UV, PQ-1
FLT121PH	PQ-1	UV, PQ-1
FLT153PH	--	--
FLT161PH	--	--
FLT173PH	UV, PQ-1	UV, PQ-1
FLT181PH	UV	UV, PQ-1
FLT193PH	PQ-1	PQ-1
FLT201PH	--	--
FLT213PH	PQ-1, PQ-2	PQ-1, PQ-2
FLT221PH	PQ-1, PQ-2	PQ-1, PQ-2
FLT233PH	UV, PQ-1	UV, PQ-1
FLT241PH	--	UV, PQ-1

UV : Gen-2003-005 Tripped due to low voltage
 OV : Tripped due to high voltage
 UF : Tripped due to low frequency
 OF : Tripped due to high frequency
 S : Stability issues encountered
 -- : Wind Farm did not trip
 PQ-1 : Prior queued project Gen-2001-026 tripped
 PQ-2 : Prior queued project Gen-2003-004 tripped

Table 7 : Stability Study Results Summary

Gen-2003-005 generators were found to be tripped for 13 contingencies out of 22 contingencies studied. The voltages at the wind generator terminals were found to be lower than the permissible levels for these 9 contingencies and hence the generators were found to be tripped by the under voltage relays. The Gen-2003-005 generators were found to stay connected to the grid for the remaining contingencies.

The prior queued projects Gen-2001-026 and Gen-2003-004 were found to be tripped for a number of cases as indicated in Table 7. Manufacturer's advanced protection package AGO4 was considered in the study for Gen-2003-004.

Figure 3 shows the system response for FLT13PH case.

With Vestas's advanced protection package, AGO4 scheme, instead of the standard package, Gen-2003-005 generators were found to stay connected to the grid for all the contingencies considered. Table 8 provides the summary of the stability studies for Gen-2003-005 with advanced protection package AGO4.

Fault Number	Summer Load	Winter Load
FLT13PH	S, PQ-1	S, PQ-1
FLT21PH	S	S
FLT33PH	--	--
FLT41PH	--	--
FLT53PH	--	--
FLT61PH	--	--
FLT73PH	--	--
FLT81PH	--	--
FLT93PH	PQ-1	PQ-1
FLT101PH	--	--
FLT113PH	PQ-1	PQ-1
FLT121PH	PQ-1	PQ-1
FLT153PH	--	--
FLT161PH	--	--
FLT173PH	PQ-1	PQ-1
FLT181PH	--	--
FLT193PH	PQ-1	PQ-1
FLT201PH	--	--
FLT213PH	PQ-1, PQ-2	PQ-1, PQ-2
FLT221PH	PQ-1, PQ-2	PQ-1, PQ-2
FLT233PH	PQ-1	PQ-1
FLT241PH	--	--

UV : Gen-2003-005 Tripped due to low voltage

OV : Tripped due to high voltage

UF : Tripped due to low frequency

OF : Tripped due to high frequency

S : Stability issues encountered

-- : Wind Farm did not trip

PQ-1 : Prior queued project Gen-2001-026 tripped

PQ-2 : Prior queued project Gen-2003-004 tripped

Table 8 : Stability Study Results Summary with AGO4

The simulation results of both winter and summer load cases indicated that there was a voltage stability problem for a fault closer to Anadarko on Anadarko – Gen-2003-005 Wind Farm 138 kV line. Figure 4 shows the system response for FLT13PH case with AGO4.

Simulations were also carried out to verify whether the voltage instability would still exist if Anadarko line was not reclosed. The results indicated that the voltage instability would still exist even if Anadarko line was not reclosed, as shown in Figure 5.

Static VAR Compensator (SVC) was considered in the study to confirm whether they would help mitigating the voltage stability problem. It was found out that an SVC of +30 MVAR would be needed at Gen-2003-005 Windfarm's 34.5 kV collector bus so as to avoid the transient voltage stability problem. Figure 6 and 7 show the system response for the contingency FLT13PH with an SVC of +30 MVAR.

7. SUMMARY

A transient stability analysis was conducted for the SPP Interconnection Generation Queue Position Gen-2003-005 with its output at 100 MW consisting of Vestas V80-1.8 MW wind turbines. The study was conducted for two different power flow scenarios, i.e., one for summer load and the other for winter load.

The study has indicated that the Vestas advanced protection scheme package AGO4 would be required for Gen-2003-005 generators in order for the generators to stay connected during the faults.

However, the study has indicated that there would a voltage stability problem for a fault closer to Anadarko on Anadarko – Gen-2003-005 wind farm 138 kV line. A Static VAR Compensator (SVC) of +30 MVAR would be needed at Gen-2003-005 Windfarm's 34.5 kV collector bus, so as to avoid the transient voltage stability problem.

The Interconnection Customer shall consider this additional risk implication of wind farm outages that the wind turbine under voltage control scheme may cause to the wind farm.

Disclaimer

If any previously queued projects that were included in this study drop out, then this System Impact Study may have to be revised to determine the impacts of this Interconnection Customer's project on SPS transmission facilities. Since this is also a preliminary System Impact Study, not all previously queued projects were assumed to be in service in this System Impact Study. If any of those projects are constructed, then this System Impact Study may have to be revised to determine the impacts of this Interconnection Customer's project on SPS transmission facilities. In accordance with FERC and SPP procedures, the study cost for restudy shall be borne by the Interconnection Customer.

Figure 3 : System Responses with 100% output of Gen-2003-005

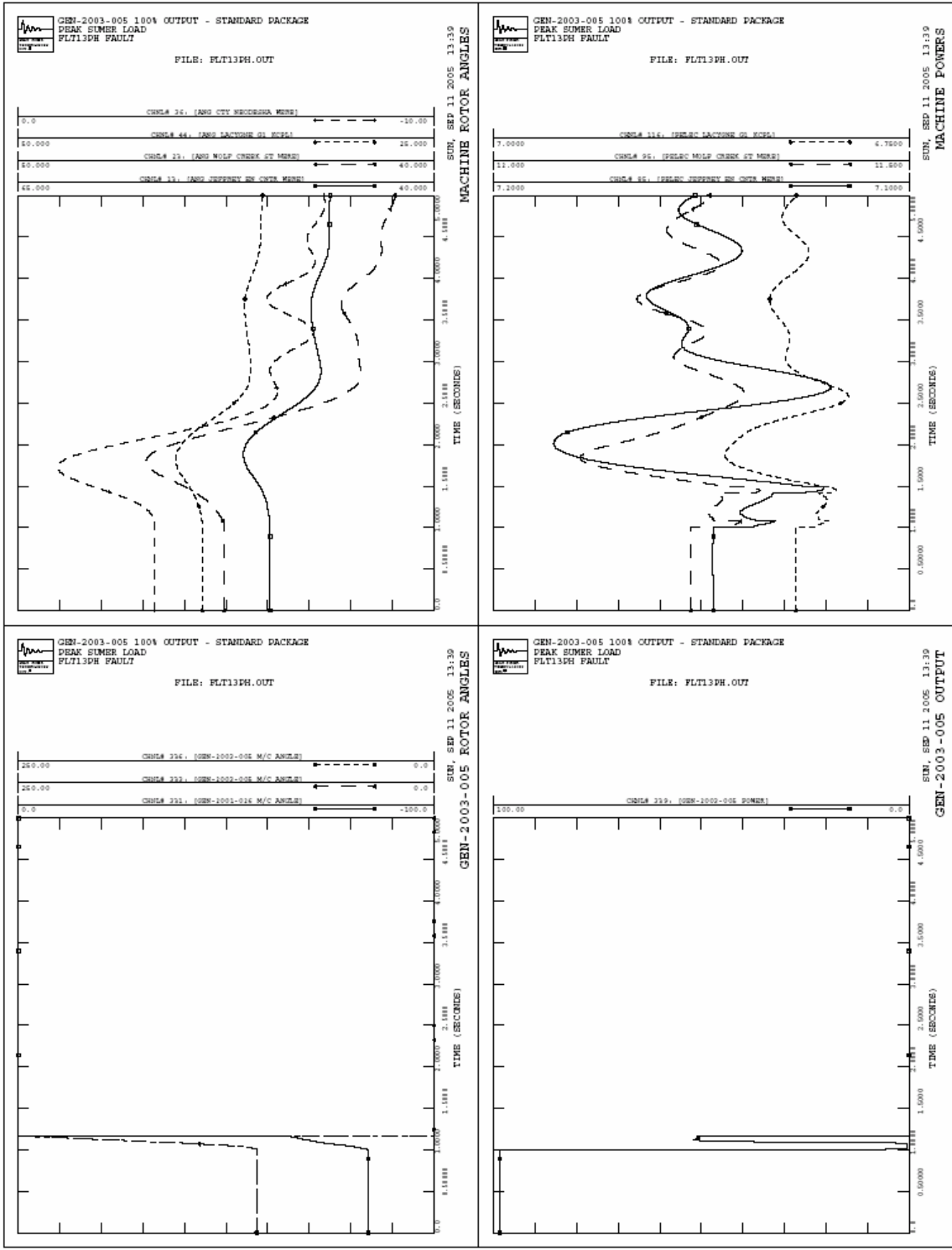

Figure 3 : System Responses with 100% output of Gen-2003-005 (Cont'd)

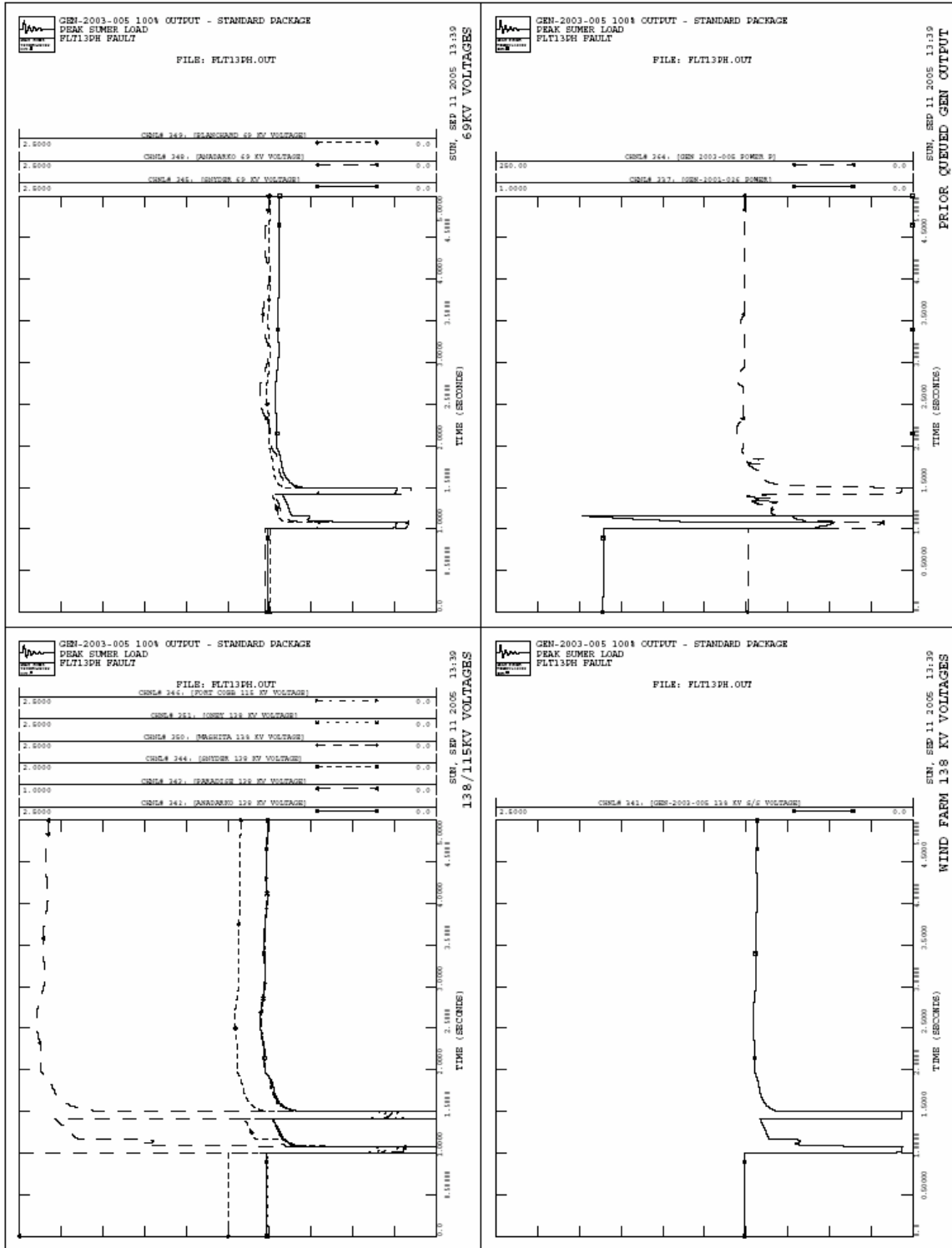

Figure 4 : System Responses with 100% output of Gen-2003-005 – with AGO4

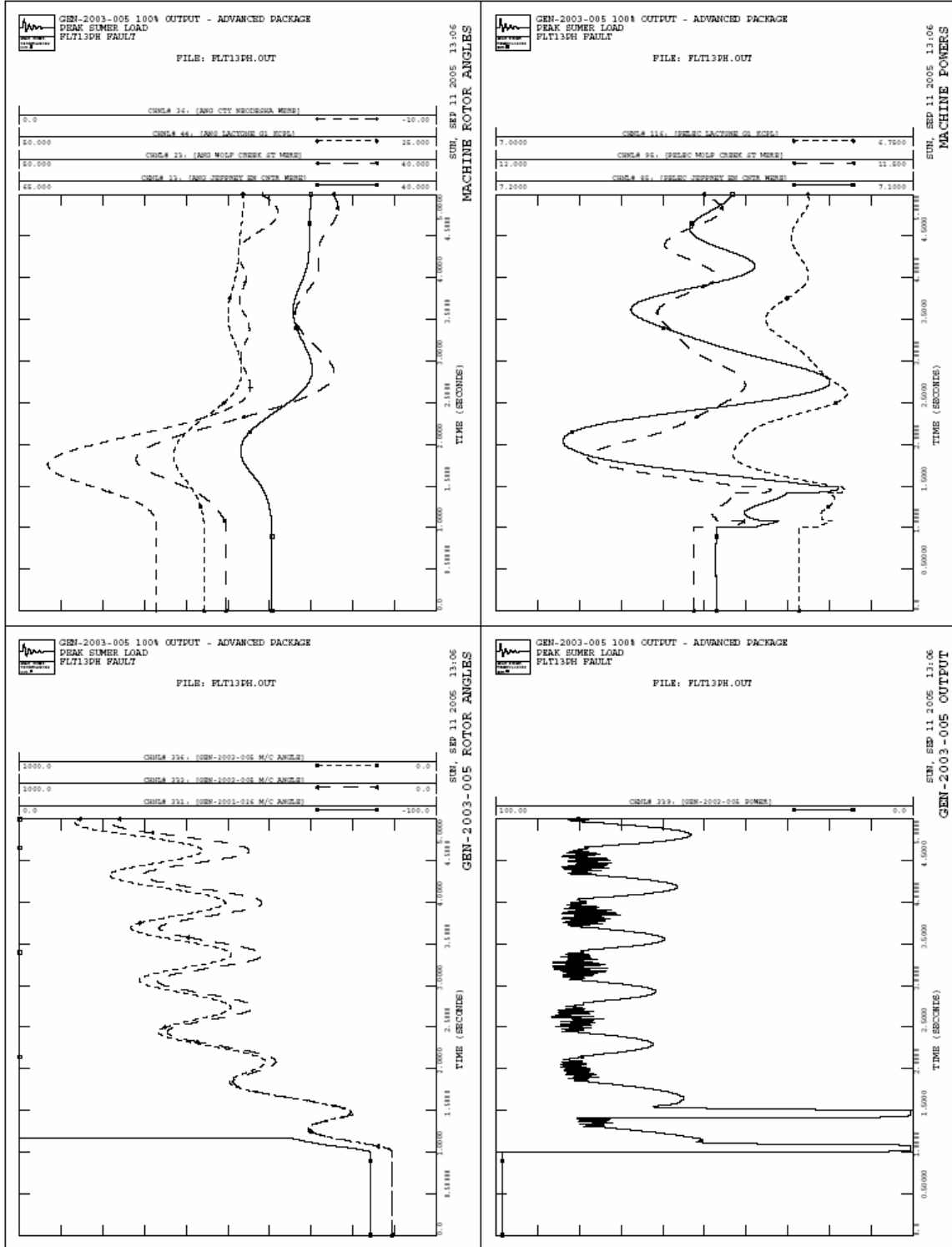
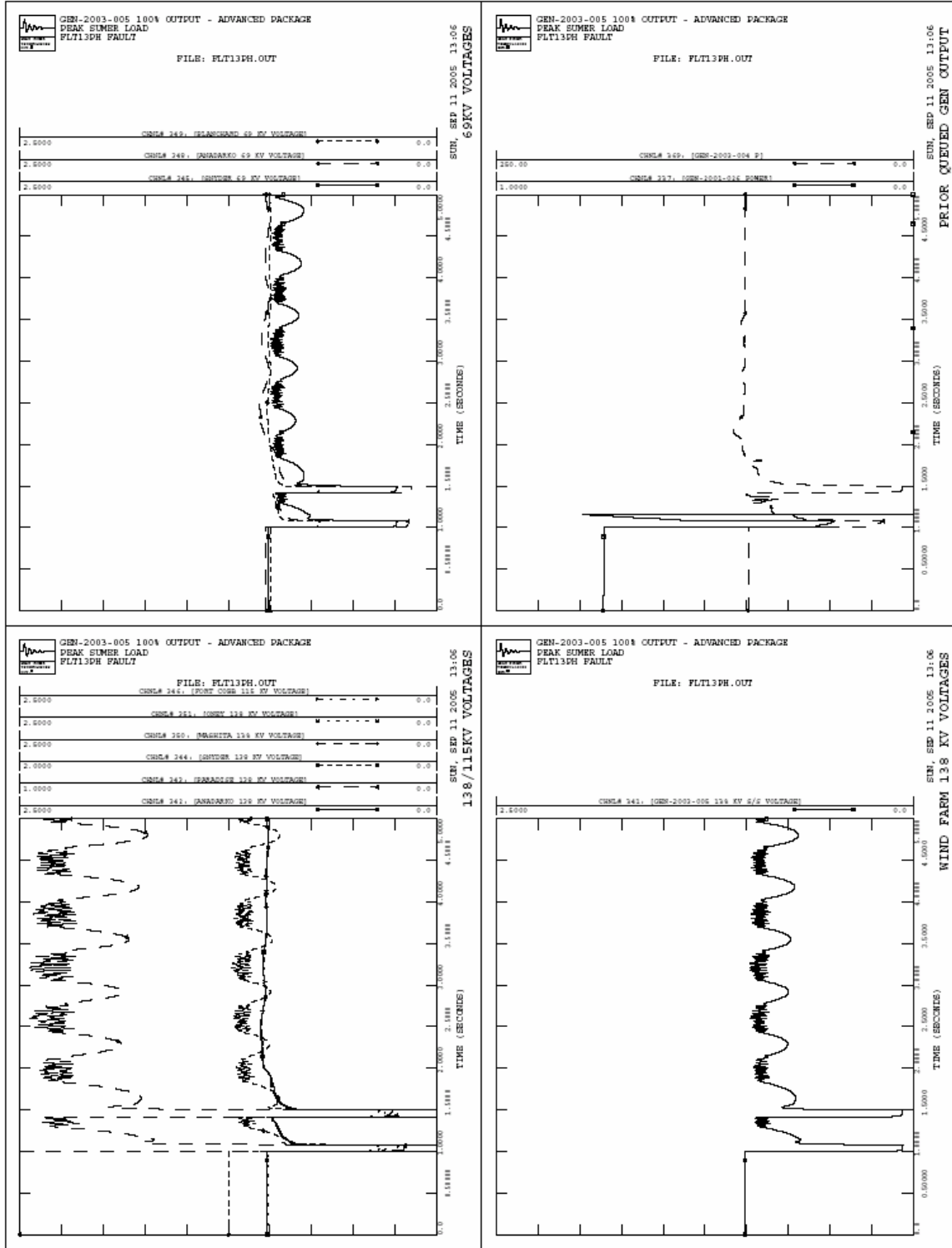

Figure 4 : System Responses with 100% output of Gen-2003-005 – with AGO4



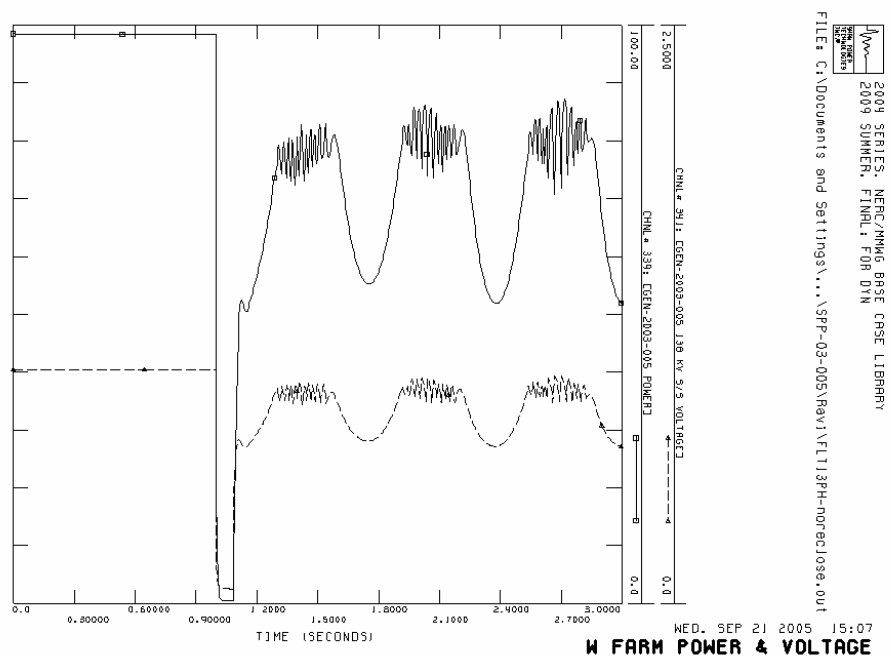

Figure 5 : Gen-2003-005 Power and Voltage for FLT13PH (without line reclose)

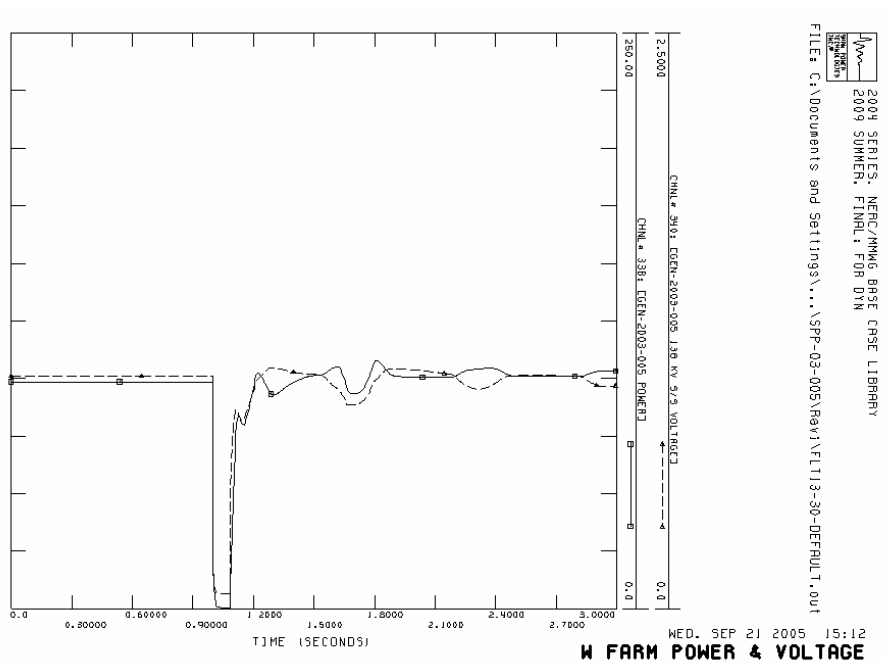

Figure 6 : Gen-2003-005 Power and Voltage for FLT13PH (with 30 MVAR SVC) – Summer Case

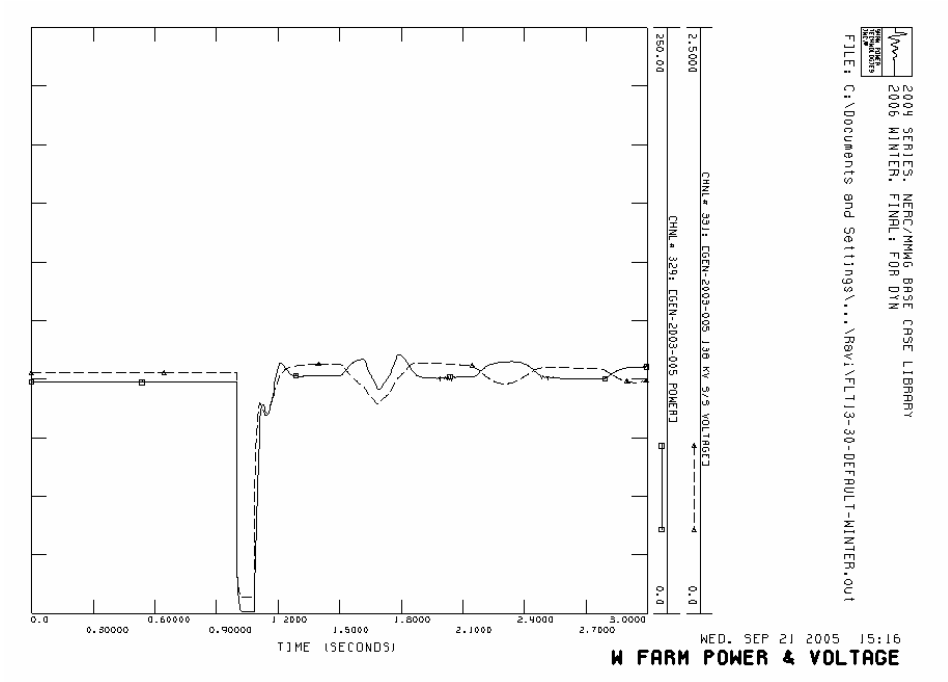

Figure 7 : Gen-2003-005 Power and Voltage for FLT13PH (with 30 MVAR SVC) – Winter Case